

## Hydraulic Bucket Grabs (Double Ram Models)

The Cashels Hydraulic Bucket Grabs are designed for use on tractor loaders. Bucket Grabs have become the most popular tool fitted to loaders because of their versatility in handling all types of material across a broad range of sectors. Cashels Bucket Grabs have been designed for use in the agricultural, amenity, construction and recycling sectors. The bucket section is uniquely designed for optimum strength and durability with removable sides for increased versatility when required. The fork grab section is also uniquely constructed and is fitted with curved stone fork tines.

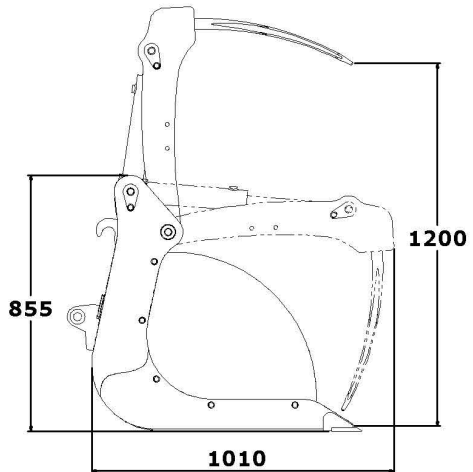
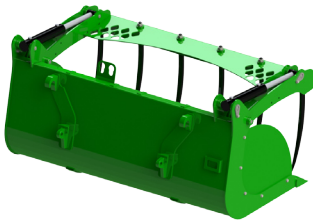

### Features:

- Unique design for optimum strength & durability
- CAT 1 stone fork tines & bushings (Optional CAT 2 tines available upon request)
- Hardened cutting edge fitted to bucket section
- Removable sides on bucket section for increased versatility
- Curved tine lengths - 680mm
- Tine Centres - Curved Tines: 300mm (Approx.)
- Various linkage options available

Model	Length (mm)	Width (mm)	Height (mm)	Opening Height (mm)	Load Capacity (m <sup>3</sup> )	Net Weight (kg)	Curved Tines
BG 1700	1010	1700	855	1200	0.65 m <sup>3</sup>	360	6

# **GREG ALLAN**

## **FARM MACHINERY**

Phone:

**5231 5136**

408 Princes Hwy, Colac West, Vic, 3249

[www.gregallanfarmmachinery.com.au](http://www.gregallanfarmmachinery.com.au)